

DRIV-NN-24V-60W

LED Driver, Constant Voltage, Class 2, 24V, 60W

DESCRIPTION

The NN series LED drivers feature flicker free lighting. This driver offers a UL Listed style enclosure which has a built-in junction box for both the input and output.

SPECIFICATIONS

- Voltage: 24V
- Watts: 60W
- Input: 120-277V 50/60Hz, 0.96A Max.
- Output: 24VDC 2.6A MAX. 96VA
- Efficiency: 87%
- THD Max. Load: <20%
- IP Rating: IP65 for both indoor and outdoor use
- Dimensions: With a Jbox: 11.84" L X 2.4" W X 1.4" H
Without a Jbox: 7.54" L X 2.4" W X 1.4" H
- Current Consumption: 0.35mA/Source
- Leads operation Temperature: -25°C-+40°C
- Max Case Temp. : -65°C
- Overload protection: CC Mode
- Auto-reset protection for short circuit & over-temperature
- Certification: UL Listed for US and Canada, Class P
- 5 Year Warranty



Project Name:

Fixture Type:



DIMENSIONS

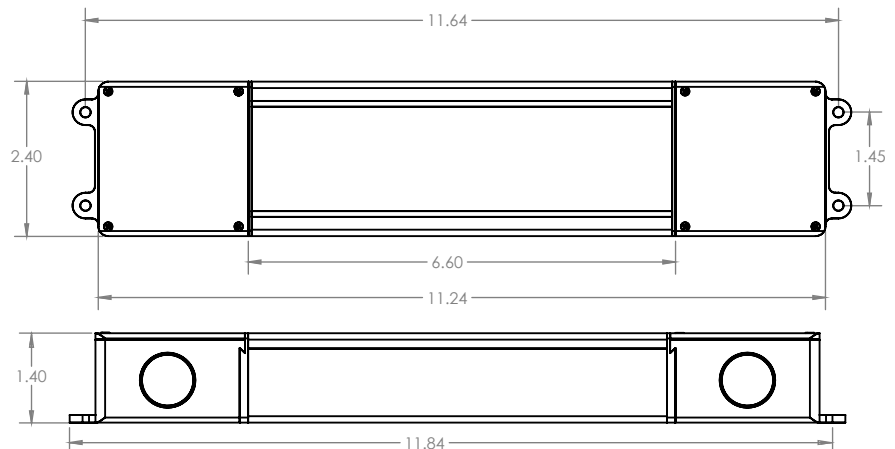
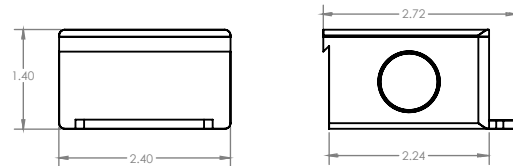
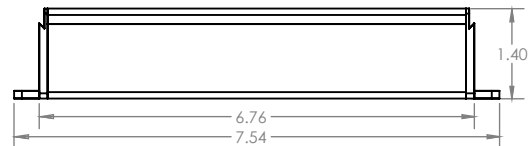
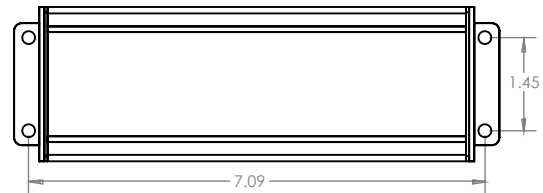

WIRING DIAGRAM

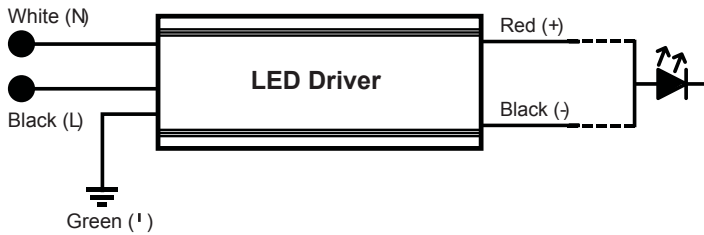

DRIV-NN-24V-60W

LED Driver, Constant Voltage, Class 2, 24V, 60W

Project Name:

Fixture Type:

■ DRIVER SELECTION INSTRUCTIONS

There are two different concepts that you need to understand when choosing a driver for your tape light project:

1) Driver calculation

2) Maximum Tape Light/Wire Length Calculation

Driver Calculation:

To calculate the driver you need, you need to make a mathematical calculation based on the tape light's wattage. We also need to calculate the fact that most of our drivers run at >80% efficiency¹.

To calculate the amount of watts required for your project, use the following formula:

$$\text{Total wattage} = \frac{\text{Watts per foot} * \text{Lenght(feet)}}{\text{Efficiency of the driver}}$$

So, for example, if you are using Hi-Beam Tape Light, which is 4.4W/ft (as stated in table 1), and you have a 10 feet run, the total wattage will be:

$$\text{Total wattage} = \frac{4.4 \text{ W/ft} * 10\text{ft}}{0.80} = 55 \text{ Watt}$$

So the minimum wattage driver you can use is 55W. Because we do not sell 55W drivers, you can round up to the closest capacity we do carry, which, in this case, is 60W. Note: All our low voltage tape light and drivers work at 24VDC.

Maximum Tape Light/Wire Length Calculation:

There is a voltage drop across tape light, which results in flickering, loss of light and change in color. You can use the same driver to power multiple run lengths of tape light, as long as each one connects back to the driver doesn't exceed the maximum continuous run length stated in table 1.

Tape Light Type	Watts Per Foot	Max one Run "foot"
Lo-Beam	1.46	52.6
Lo-Beam Wet	1.46	52.6
Beam	2.93	26.24
Beam Wet	2.93	26.24
Hi-Beam	4.4	17.5
Hi-Beam Wet	4.4	17.5
Hi-Beam RGB	4.4	17.5
Hi-Beam Line Voltage	2.93	26.25
Beam Double	5.85	13.12
Beam Double Wet	5.85	13.12
Hi-Beam Double	8.8	8.75
Hi-Beam Double Wet	8.8	8.75
Ultra-High Beam	8.78	8.75

DRIV-NN-24V-60W

LED Driver, Constant Voltage, Class 2, 24V, 60W

Project Name:

Fixture Type:

However, there is a maximum length of wire between the driver and the tape light that you can use due to the voltage drop across the wire. To calculate the maximum length of wire to use, use the following wire resistance chart and equations or the voltage drop chart at each tape light's page on our website under downloads section. Please note that the maximum length of the wire depend on the length of the tape light that you will use

Wire Gauge	12AWG	14AWG	16AWG	18AWG
Resistance per ft.	0.001588	0.002525	0.00402	0.00639

$$\text{Current(Amps)} = \frac{\text{Power (Watt)}}{\text{Voltage (Volt)}}$$

$$\text{Voltage drop} = \text{Resistance per foot} * \text{Lenght of wire(feet)} * \text{Current}$$

Voltage drop across the wire should be less than 3% to avoid flickering, loss of light and change in color (which mean it should be less than 0.72 Volts as all of our tape light works with 24 VDC)

For example, if we are using Hi-Beam Tape Light , which is 4.4W/ft, and you have a 10 foot run of the tape light, and want to use 20 feet of 16AWG you use the following equation:

$$\text{Current} = \frac{4.4 * 10}{24} = 1.83$$

$$\text{Voltage drop} = 0.00402 * 20 * 1.83 = 0.147 \text{ Volt}$$

The voltage drop is less than 0.72 volt So this configuration is suitable.

Click [here](#) for a more detailed Driver Overview.