

Figure Tall Trimmed Channel

TAPE LIGHT CHANNEL

Project Name:

Fixture Type:

DESCRIPTION

PreciseLED's aluminum channels are a required companion to our tape light modules. With excellent heat sinking and light diffusion capabilities, our channels can also be custom cut and/or painted to virtually any specification. The unique design of the Figure Channel allows for many applications including installation in visible and hidden spaces, with a wide range of compatible tape light options.

SPECIFICATIONS

- Dimensions: 1.35"W x 1.11" H
- Materials: Aluminum/PC
- Maximum Width of LED Tape: 0.76"

COMPATIBILITY

The Figure Tall channel is compatible with the following tape lights:

- Lo Beam
- Lo Beam Wet
- Beam
- Beam Wet
- Hi Beam
- Hi Beam Wet
- Hi Beam Hi Efficacy
- Hi Beam Hi Efficacy Wet
- Hi Beam RGB
- Hi Beam RGB Wet
- Hi Beam RGBW
- Hi Beam RGBW Wet
- Cool Beam
- Cool Beam wet
- Ultra Beam



FINISH



Aluminum



Powder coated
Black



Powder coated
White

DIMENSIONS

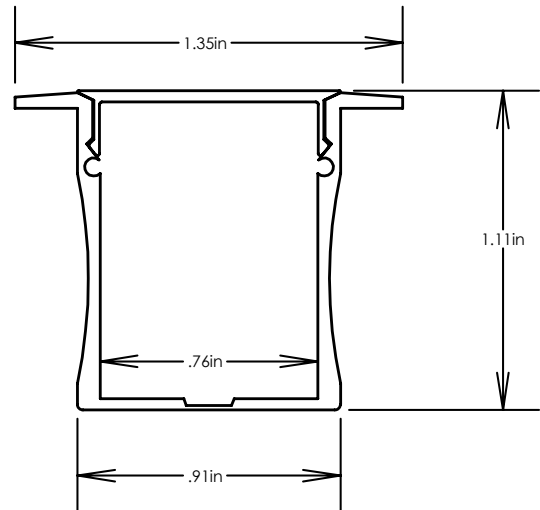

ORDERING CODE

Example: **FGTT-8-BK**

Product	Length	Finish
FGTT		
FGTT	8 8 Feet XX Length ft in	AL Aluminum- Standard BK Powder Coated Black WT Powder Coated White

Figure Tall Trimmed Channel

ACCESSORIES:

Accessory	Product	Length
Clear Lens	FGTT-CLNS	8 8 Feet XX Length ft in
Diffused Lens	FGTT-DLNS	8 8 Feet XX Length ft in
Opal Lens	FGTT-OLNS	8 8 Feet XX Length ft in
Clips/Screws (Recommended 1 set for every 2 ft length of channel)	FGTT-CLIP	
End Caps	FGTT-CAPS	
Beginning Caps (with holes)	FGTT-CAPH	

FGTT-CLIP

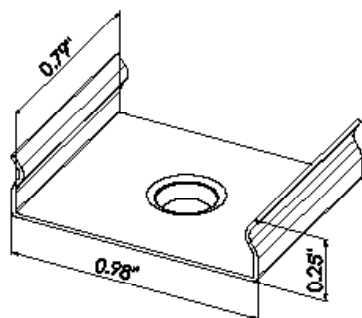
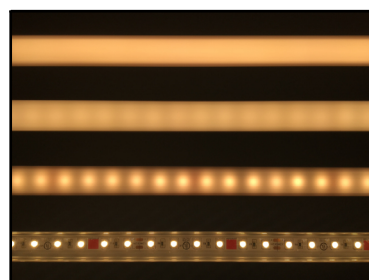

Figure Tall Trimmed Channel

■ Level of Spotlessness per Tape Light / Lens Combination

	Opal Lens	Diffuse Lens	Clear Lens
Lo-Beam	SS	SS	CL
Lo-Beam Wet	SS	SS	CL
Beam	SL	SL	CL
Beam Wet	SL	SL	CL
Hi-Beam	SS	SS	CL
Hi-Beam Wet	SS	SS	CL
Hi Beam Hi Efficacy	SL	SL	CL
Hi Beam Hi Efficacy Wet	SL	SL	CL
Hi Beam RGB	SS	SS	CL
Hi Beam RGB Wet	SS	SS	CL
Hi Beam RGBW	SS	SS	CL
Hi Beam RGBW Wet	SS	SS	CL
Cool Beam	SL	SL	CL
Cool Beam wet	SL	SL	CL
Ultra Beam	SL	SL	CL



SL = Spotless

SS = Slightly Spotty

SP = Spotty

CL = Clear