

Novation 3" LED Essential Downlight

Driver Replacement Instructions

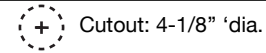

- For your safety, read and understand instructions completely before starting installation

Note: PreciseLED recessed fixtures are designed to meet the latest NEC requirements and are listed in full compliance with UL 1598. Before attempting installation of any recessed lighting fixture, check your local electrical building code. This code sets the wiring standards and installation requirements for your locality and should be understood before starting work. If fixture is to be switch from wall switch or dimmer, make sure black supply wire properly connected to switch or dimmer (follow switch/dimmer instructions).

- **WARNING:**

1. Before wiring to power supply, turn off electricity at the fuse or circuit break box.
2. Insulation may be placed in direct contact with ANY part of the fixture.
3. Always have installation performed by a licensed electrician.

- **DRIVER REPLACEMENT INSTRUCTIONS**

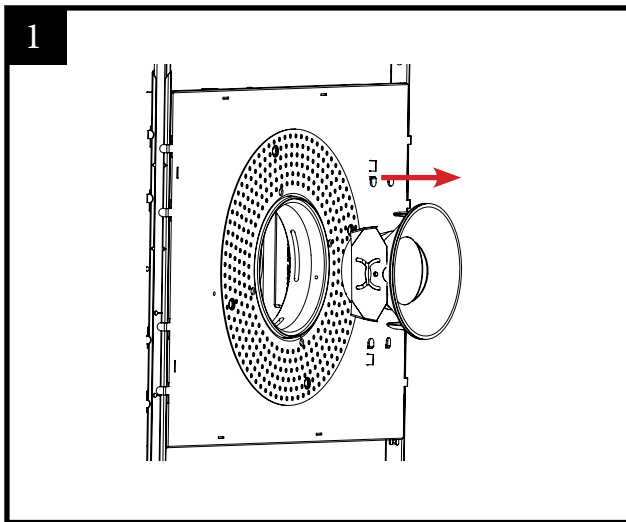

1. Remove the trim from the fixture by pulling both sides.

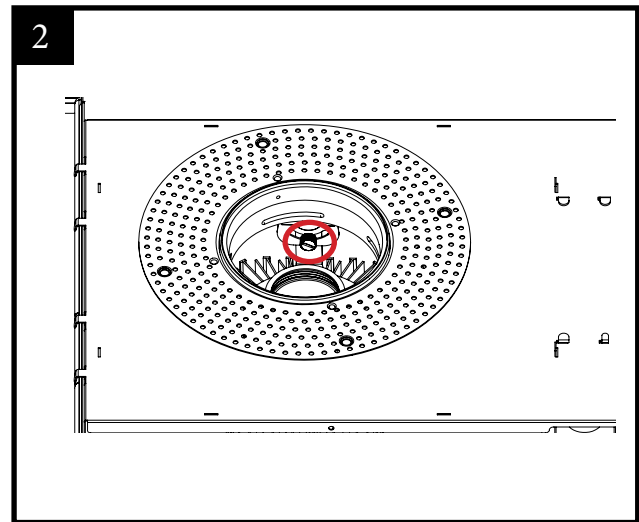

2. Loosen the two parallel locking nuts inside the fixture to be able to freely move the light.

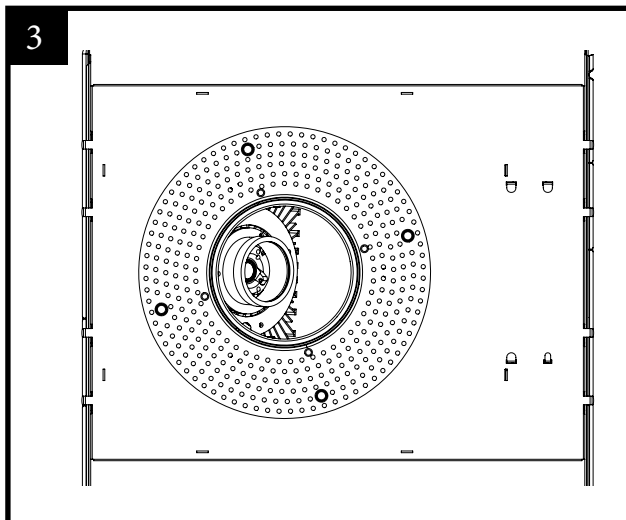

3. Push on the lens holder so that the light is at an angle.

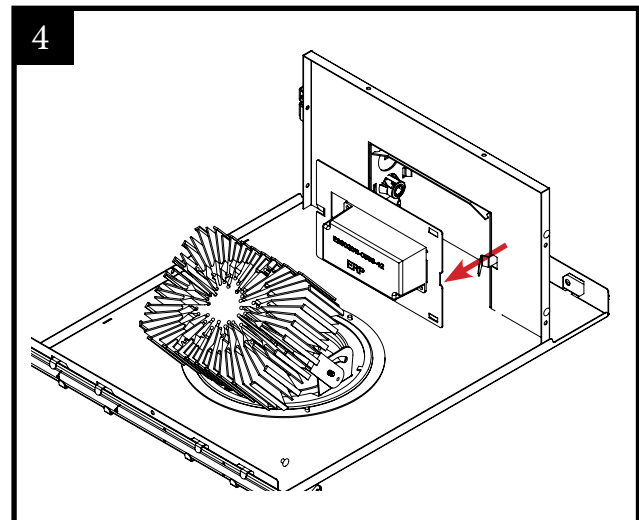

4. From the new opening, reach inside the fixture to unhook the door to the junction box, with the driver attached.

Novation 3" LED Essential Downlight

Driver Replacement Instructions

+ Cutout: 4-1/8" 'dia.

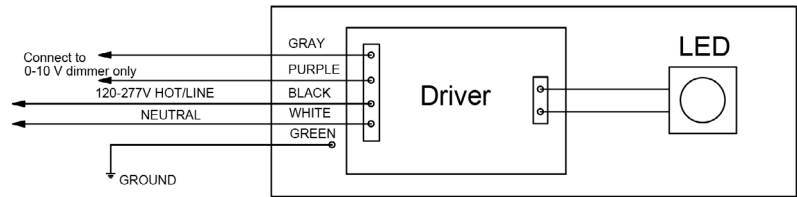
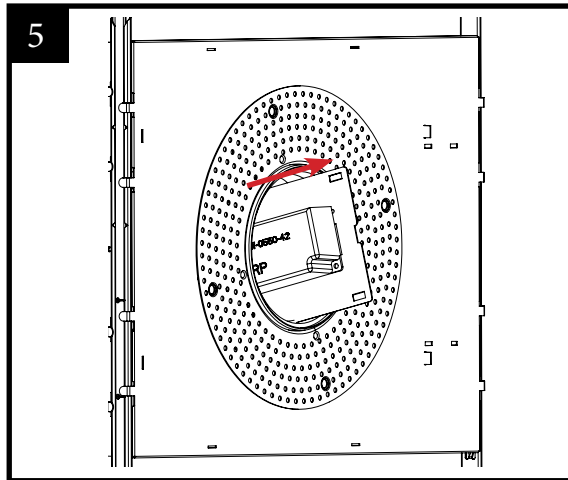

* Compatible with 0-10 V/ forward & reverse phase dimming

Note: Cap off purple and gray wires individually if 0-10 v dimming is not desired.

5. Pull out the plate with driver attached, and detach any connecting wires. Replace driver with replacement driver. See wiring diagram for additional information on wiring.

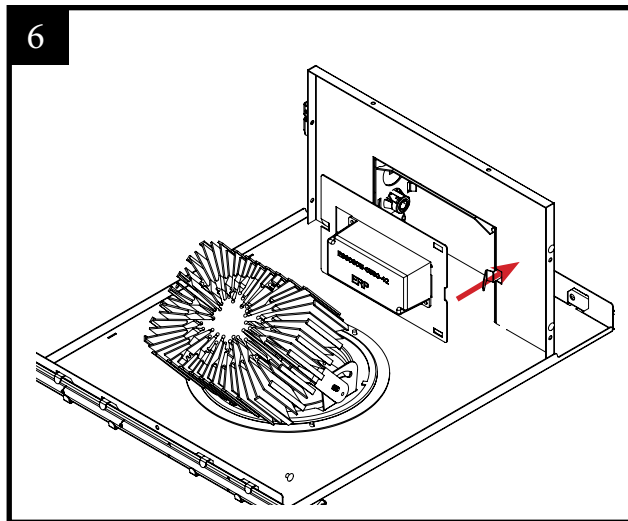

6. With the new driver attached, insert the junction box plate back and make sure all wires are inside the junction box.

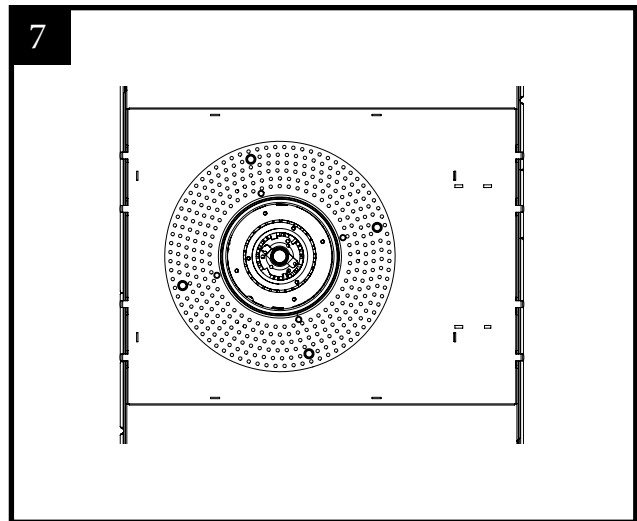

7. Return the light back to its original position and tighten the two locking nuts.

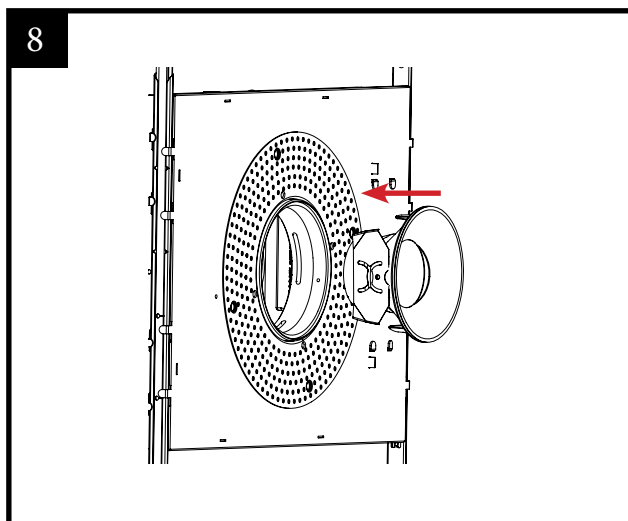

8. Snap the trim back into place. Voila!